

# P200

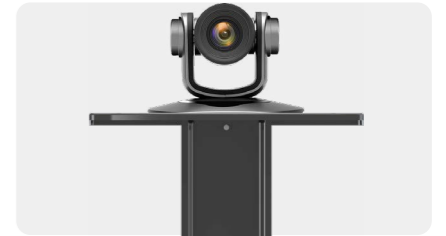

**QUICK RELEASE WHEEL LOCKS**  
Lockable casters provide easy mobility on a variety of floor types



**CONVENIENT TOP SHELF**  
Ideal for web cameras



**MIDDLE EXQUISITE TRAY DESIGN**  
Convenient storage for some small gadgets

Color |

Model No.	P200
Screen size	60"-100"
Capacity	200lbs (90.9kg)
VESA	400×200-900×600mm
Upright	9.85"(250mm)

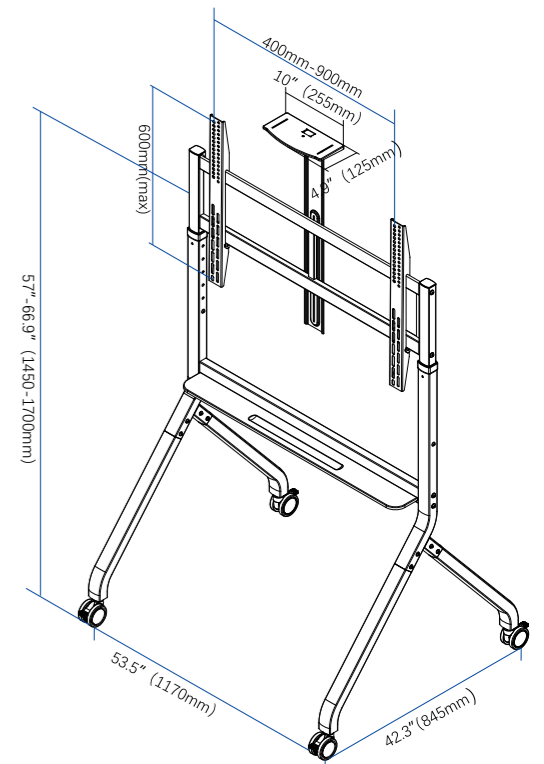
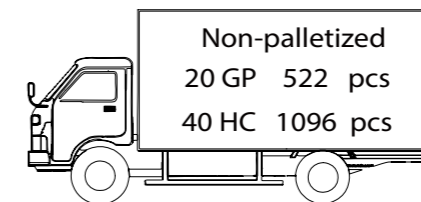
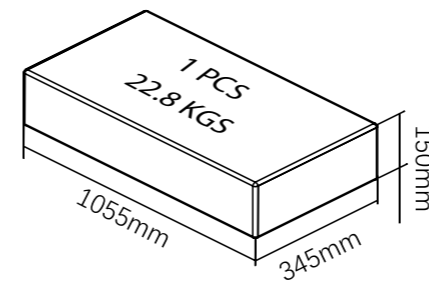

**► HEIGHT ADJUSTABLE HEAVY DUTY MOBILE TV CART**  
The sturdy and durable frame features strength to safely hold your large screen.